

1. Part Number: A746-10

2. Photograph:

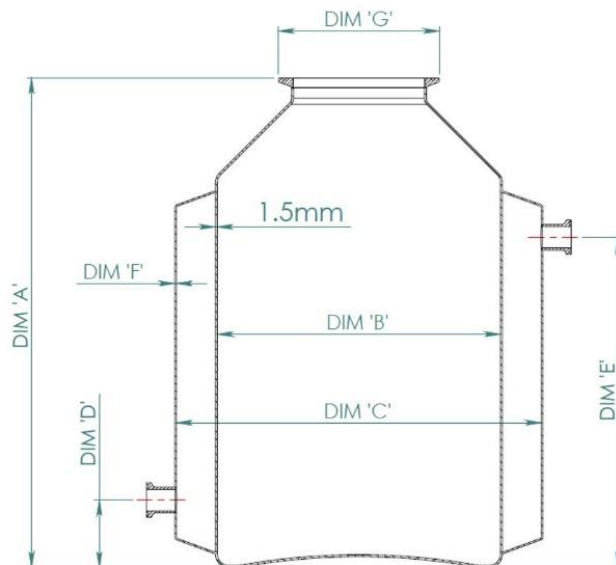

3. Product Information:

Description:

Jacketed Container 10L

Materials of Construction:

- Body: 316L stainless steel
- Lid: 316L stainless steel
- Clamp: 304 stainless steel
- Gasket: Silicone (FDA acceptable grade)

Method of Construction:

All welds ground and polished
Crevice free interior

Surface Finish:

Better than 0.5 microns Ra

Nominal Volume:

10L

Dimensions:

A = 363mm
B = 210mm
C = 240mm
D = 50mm
E = 260mm
F = 1.2mm
G = 119mm

Neck / Lid Size:

4" BS4825-3

Jacket Inlet/Outlet Size:

Compatible with 1" and 1.5" tri-ferrule connections BS4825-3



BSE/TSE statement:

All polishing compounds used in the manufacture of this product are of vegetable origin.

Weight:

6.3 Kg (body + lid + gasket + clamp)

Recommended Storage Conditions:

Dry and ambient temperature

4. Approval:

Signed:



Name: Kuldeep Flora

Position: Quality Manager

Date: 13-Mar-25